

Wrist Lacer

FITTING INSTRUCTIONS

W A R N I N G S

CAUTION: FOR SINGLE PATIENT USE ONLY.

CAUTION: IF YOU EXPERIENCE INCREASED PAIN, SWELLING, OR ANY ADVERSE REACTIONS WHILE USING THIS PRODUCT, IMMEDIATELY CONSULT YOUR MEDICAL PROFESSIONAL.

WARNING: CAREFULLY READ FITTING INSTRUCTIONS AND WARNINGS PRIOR TO USE.

WARNING: THIS DEVICE WILL NOT PREVENT OR REDUCE ALL INJURIES. PROPER REHABILITATION AND ACTIVITY MODIFICATION ARE ALSO AN ESSENTIAL PART OF A SAFE TREATMENT PROGRAM.

BREG.
 Breg, Inc.
 2885 Loker Ave. East
 Carlsbad, CA 92010 U.S.A.
 P: 800-321-0607
 F: 800-329-2734
 www.breg.com
 © 2013 Breg, Inc.
 AW-1.90207 REV B 0113

8" and 10" Wrist Lacer:

Example illustrates left hand brace application.

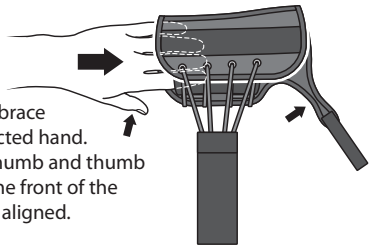
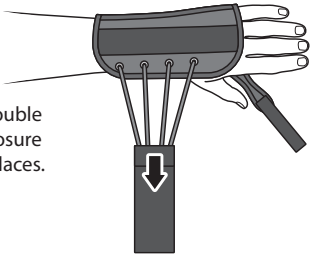
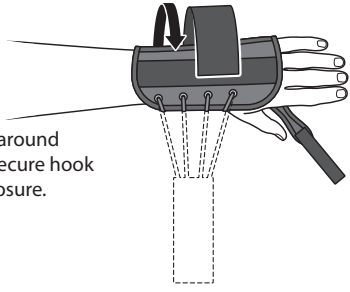
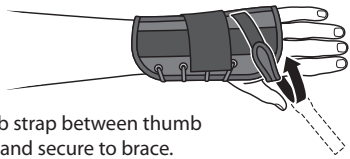
- 1**  Slide the brace onto affected hand. Be sure thumb and thumb strap at the front of the brace are aligned.
- 2**  Pull single (or double if 10" version) closure strap to tighten laces.
- 3**  Wrap strap around brace and secure hook and loop closure.
- 4**  Close thumb strap between thumb and fingers and secure to brace.

Wrist Lacer with Thumb Spica:

Example illustrates right hand brace application.

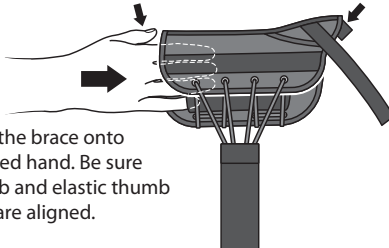
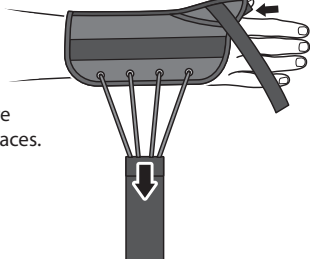
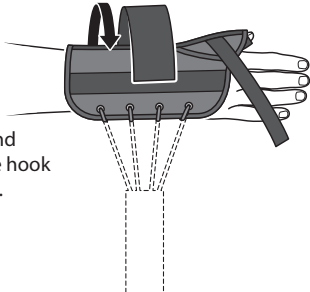
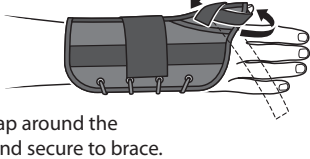
- 1**  Slide the brace onto affected hand. Be sure thumb and elastic thumb loop are aligned.
- 2**  Pull single closure strap to tighten laces. Slide thumb into elastic loop.
- 3**  Wrap strap around brace and secure hook and loop closure.
- 4**  Wrap thumb strap around the injured thumb and secure to brace.

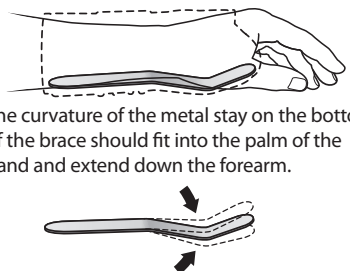
 The curvature of the metal stay on the bottom of the brace should fit into the palm of the hand and extend down the forearm.

If necessary, remove the malleable metal stay (see at right) and bend it to the appropriate position.

 Trim hook and loop closure strap(s) leaving approximately 1" - 2" of overlap.

 **Washing Instructions:** Remove metal stay. Fasten hook and loop closures. Hand wash in warm water using a mild detergent. Air dry.